

EXPLODED VIEW & PARTS LISTING

Air Operated Double Diaphragm Pump

Model: NDP-25BSH-FDA

Part#: 852102-FDA

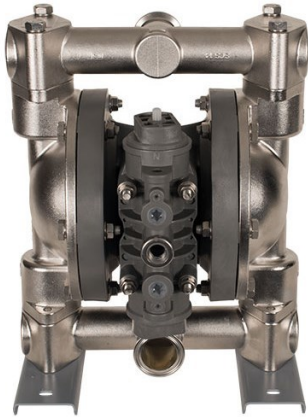

To Purchase:

☎ 800-990-7867

✉ sales@yamadapump.com

📍 Find My Rep

More Information:

▶ YouTube: @yamadapump

🌐 yamadapump.com

Data Sheets | CAD Drawings | Manuals
Literature | BOM | Performance Curves

Trial Program

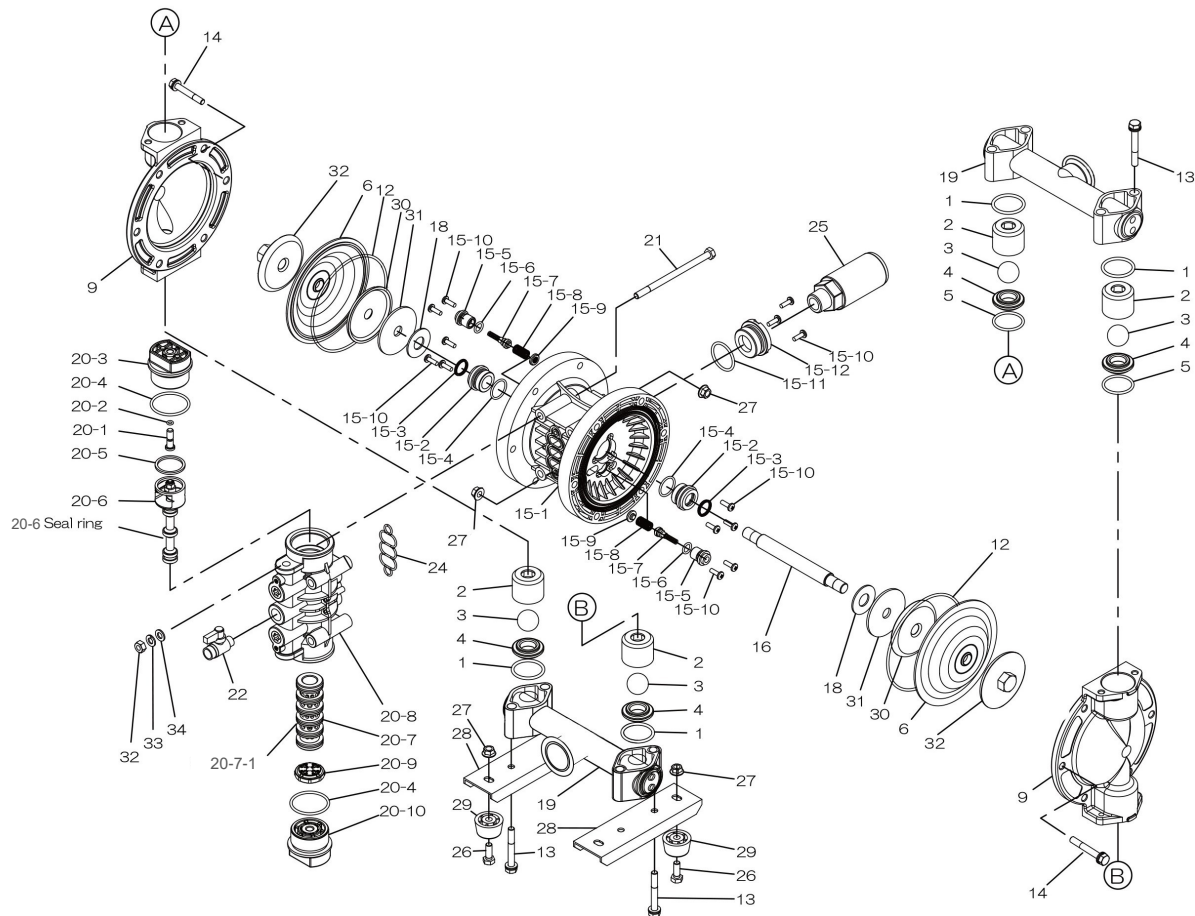

Air Operated Double Diaphragm Pump

Ref. No.	Part No.	Description	Qty.	Reorder
1	643044	O-ring	4	
2	711703-EP	Valve Stopper	4	
3	770691	Ball	4	
4	711707-EP	Valve Seat	4	
5	771130	O-ring	2	
6	771363	Diaphragm	2	
9	711694-EP	Out Chamber	2	
12	640154	O-ring	2	
13	621185	Bolt	8	
13a	631937	Wave Washer	8	
14	621181	Bolt	12	
14a	631937	Wave Washer	12	
15	804604	Body Assembly	1	
15-1	772929	Body	1	
15-2	780326	Throat Bearing	2	
15-3	685414	Packing	2	
15-4	685276	O-ring	2	
15-5	772932	Valve Seat	2	
15-6	640009	O-ring	2	
15-7	802360	Pilot Valve Assembly	2	
15-8	708666	Spring	2	
15-9	772948	Spring Seat	2	
15-10	686030	Tapping Screw	13	
15-11	640132	O-ring	1	
15-12	772933	Bushing	1	
16	710271	Center Rod	1	
18	771054	Cushion	2	
19	831271-TC-EP	Manifold	2	
20	804608	Valve Body Assembly	1	
20-1	772991	Rest Button	1	
20-2	640002	O-ring	1	
20-3	772946	Cap A	1	
20-4	640043	O-ring	2	
20-5	771241	Packing	1	
20-6	802400	C Spool Valve Assy.	1	
20-6 seal	771053	Seal Ring	5	
20-7	804609	Sleeve Assembly	1	
20-7-*1	686029	O-ring	6	
20-8	832903	Valve Body Assembly	1	
20-9	771914	Cushion	1	
20-10	772947	Cap B	1	
21	686031	Bolt	4	
22	686970	Ball Valve	1	
24	772848	Gasket	1	
25	804697	Silencer	1	
26	621149	Bolt	4	
27	686032	Nut with Flange	16	
28	709156-XP	Pump Base	2	
29	770551	Cushion	4	
30	709151	Center Disk	2	
31	709150	Plain Washer	2	
32	709151-EP	Out Center Disk	2	
32a	683635	NUT	4	
33	681300	SPRING WASHER	4	
34	631329	FLAT WASHER	4	
KIT	K25-MH-FDA	LIQUID END KIT		
KIT	K225-AP	AIR MOTOR KIT		

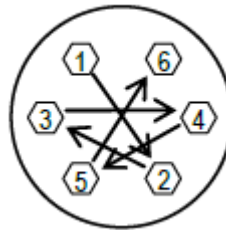

Tightening torque for center rod and out chambers.

Center Rod 29 ft-lbf (40 N-m)
Out Chambers 8 ft-lbf (10 N-m)

Tightening torque for manifold retainer bolts.

BSH-FDA 8 ft-lbf (10 N-m)

General Tools:

- Socket wrenches - 10mm, 12mm, 13mm, 17mm, 22mm
- Hexagonal box wrench - 5mm
- Open-end wrench - 22mm

Miscellaneous:

- Assembly oil - turbine oil non additional class 1 (equivalent to ISO VG32 grade)
- Nuts - M14 x 1.5
- Urea grease grade (NLGI) No. 2
- Lubricants (equivalent to Loctite Anti-Seize 767)

Customer Notes

Model #: _____
 Description: _____
 Serial #: _____
 Date Installed: _____
 Department Location: _____
 Tag/Project: _____