

EXPLODED VIEW & PARTS LISTING

Air Operated Double Diaphragm Pump

Model: NDP-50BST-FDA

Model #: 852648-FDA



To Purchase:

☎ 800-990-7867

✉ sales@yamadapump.com

📍 Find My Rep

More Information:

▶ YouTube: @yamadapump

🌐 yamadapump.com

*Data Sheets | CAD Drawings | Manuals
Literature | BOM | Performance Curves*

Trial Program

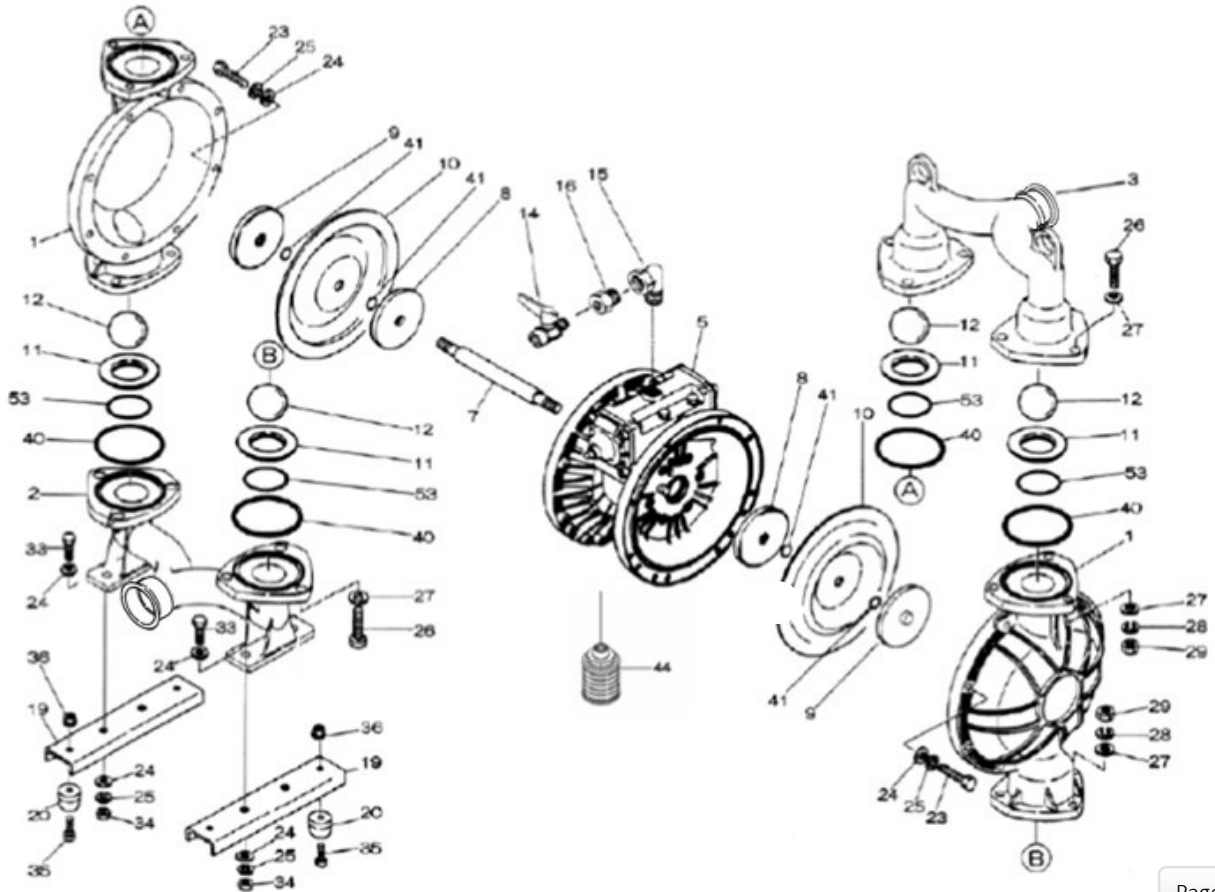

Air Operated Double Diaphragm Pump

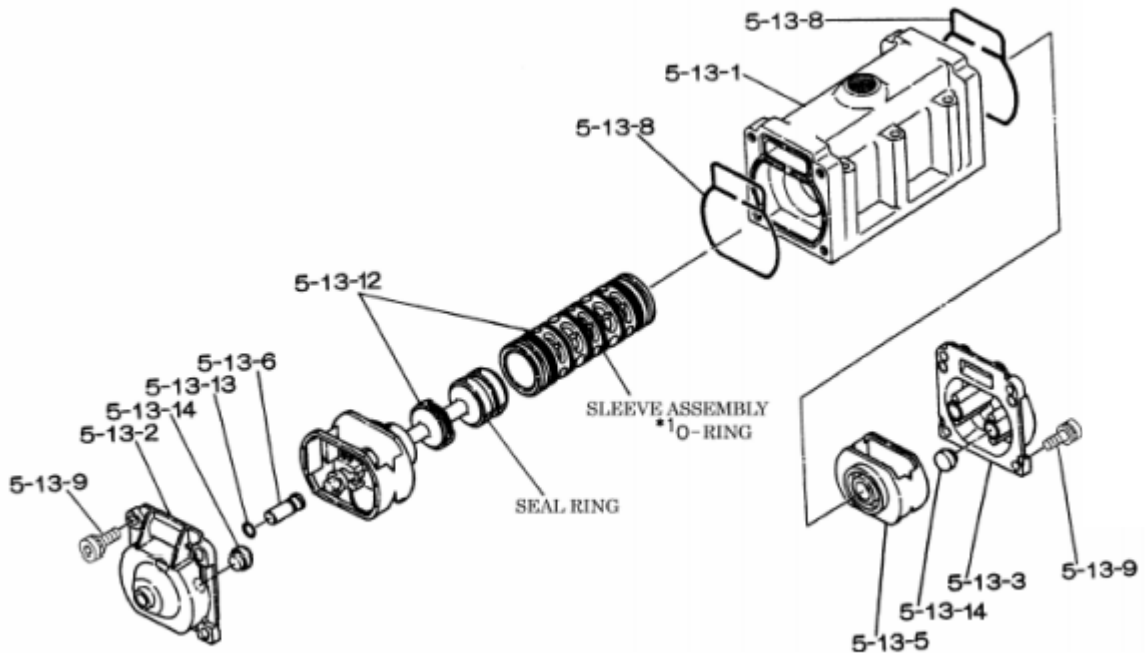
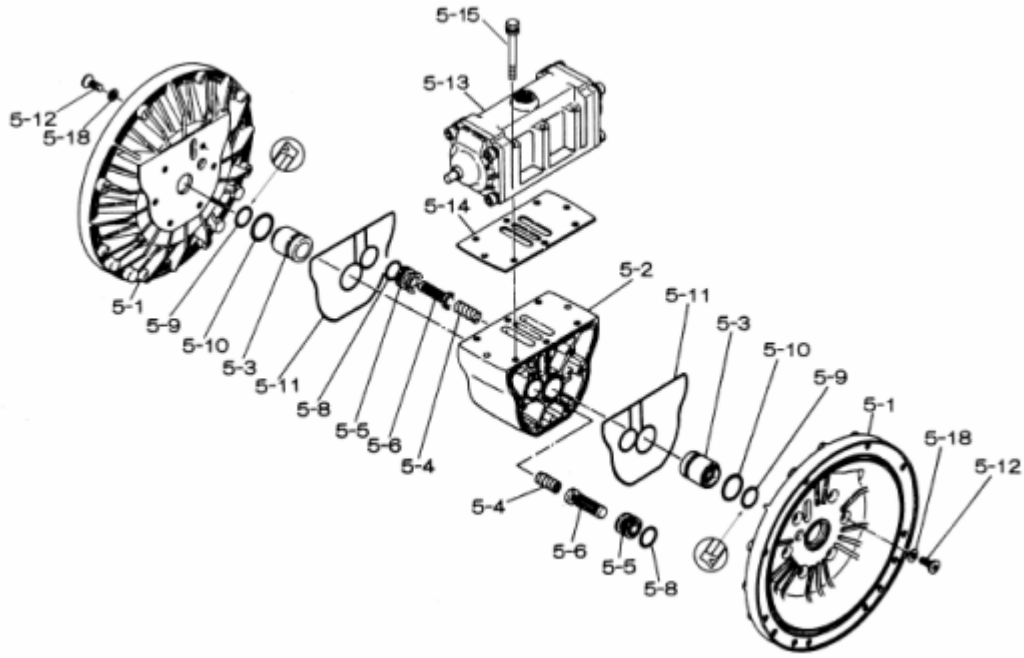

Air Operated Double Diaphragm Pump

Ref. No.	Part No.	Description	Q'ty	Reorder
1	712932-EP	Out Chamber	2	
2	712559-TC-EP	In Manifold - NPT	1	
3	712558-TC-EP	Out Manifold - NPT	1	
5	803112-XP	Body Assembly	1	
5-1	711934-XP	Air Chamber	2	
5-2	711936-XP	Body	1	
5-3	772689	Throat Bearing	2	
5-4	711937	Spring	2	
5-5	771740	Pilot Valve Seat	2	
5-6	832162	Pilot Valve Assembly	2	
5-8	640020	O-ring	2	
5-9	685444	Packing	2	
5-10	640029	O-ring	2	
5-11	771742	Gasket	2	
5-12	683812-S	Flat Head Bolt	12	
5-13	802971-XP	Valve Body Assembly	1	
5-13-1	711931-XP	Valve Body	1	
5-13-2	580999-XP	Cap A	1	
5-13-3	581000-XP	Cap B	1	
5-13-5	771735	Spring Stopper	1	
5-13-6	712976-S	Reset Button	1	
5-13-8	771738	Gasket	2	
5-13-9	685036	Bolt	8	
5-13-12	805084	C Spool Valve Assy.	1	
5-13-12 *1 Sleeve	803675	Sleeve Assembly	1	
5-13-13	640005	O-ring	1	
5-13-14	684128	Cushion	4	
5-14	771712	Gasket	1	
5-15	684240-S	Bolt	6	
5-18	684987	Plain Washer	12	
7	711939	Center Rod	1	
8	707822	Center Disk	2	
9	707823-EP	Center Disk	2	
10	770815	Diaphragm	2	
11	711909-EP	Valve Seat	4	
12	770693	Ball	4	
14	686974	Ball Valve	1	
15	682523	Elbow	1	
19	711928-XP	Pump Base	2	
20	771402	Cushion	4	
23	621180	Bolt	16	
24	631174	Plain Washer	4	
25	631937	Wave Washer	20	
26	621202	Bolt	12	
27	631175	Plain Washer	12	
28	631938	Wave Washer	12	
29	628014	Nut	12	
33	621175	Bolt	4	
34	628013	Nut	4	
35	611149	Bolt	4	
36	682276	Nut with Flange	4	
40	643069	O-ring	4	
41	643015	O-ring	4	
44	804764	Silencer	1	
53	643139	O-ring	4	
KIT	K50-MT	LIQUID END KIT		
KIT	K45-AM	AIR MOTOR KIT		

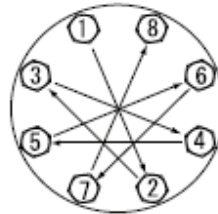

Tightening torque for center rod and out chambers.

Center Rod 43 ft-lbf (60 N-m)
Out Chambers 29 ft-lbf (40 N-m)

Tightening torque for manifold retainer bolts.

BST-FDA 15 ft-lbf (20 N-m)

General Tools:

- Socket Wrenches: 13mm, 17mm, 19mm, 24mm
- Hexagonal Box Wrenches: 5mm, 6mm
- Open-end wrenches: 19mm, 24mm

Special Tools:

- Sleeve Remover (713180) (sold separately)

Miscellaneous:

- Assembly oil - turbine of none additional class 1 (equivalent to ISO VG32 grade)
- Nuts - M16 x 1.5
- Thread Locker
- Grease - Urea grease grade (NLGI) No. 2

Customer Notes

Model #: _____
 Description: _____
 Serial #: _____
 Date Installed: _____
 Department Location: _____
 Tag/Project: _____