

# EXPLODED VIEW & PARTS LISTING

## Air Operated Double Diaphragm Pump

Model: NDP-40 Stainless Steel-HP  
High Pressure Pumps



### To Purchase:

- ☎ 800-990-7867
- ✉ sales@yamadapump.com
- 📍 Find My Rep

### More Information:

- ▶ YouTube: @yamadapump
- 🌐 yamadapump.com
- Data Sheets | CAD Drawings | Manuals Literature | BOM | Performance Curves*

### Trial Program

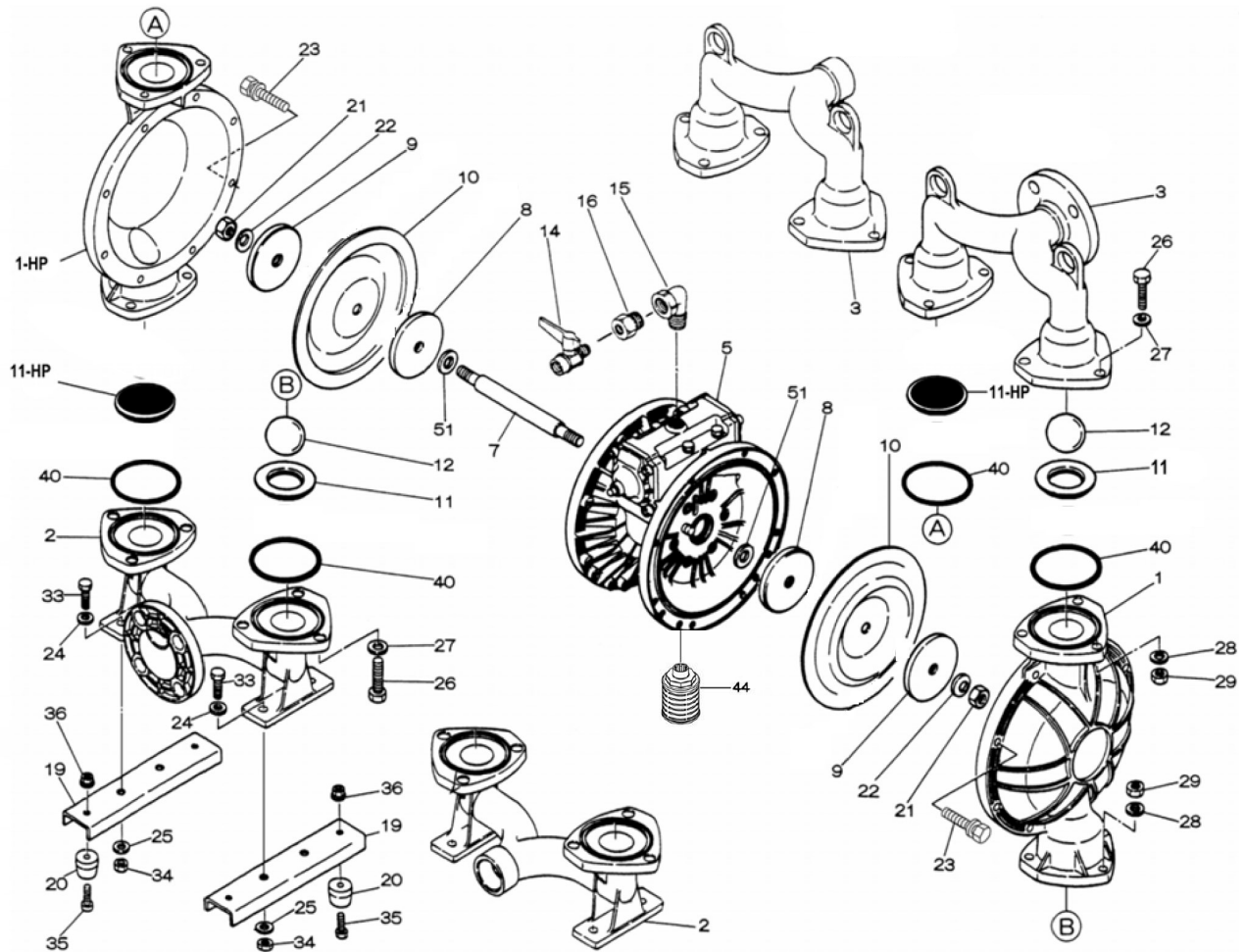

Air Operated Double Diaphragm Pump

■ Body Assembly

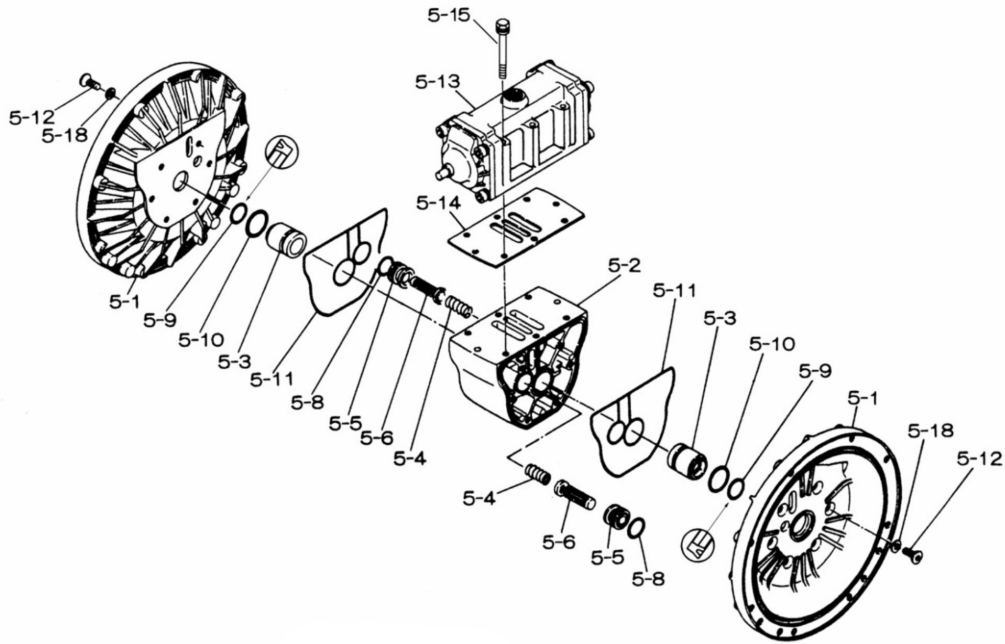

■ Valve Body Assembly

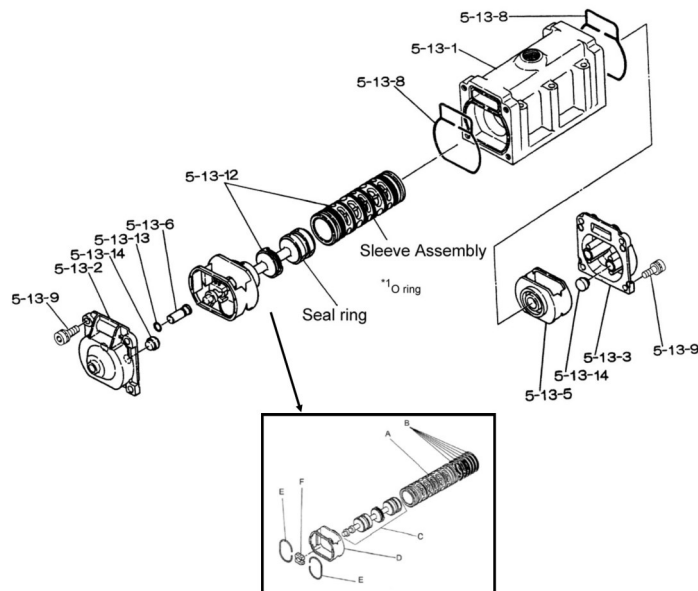

Air Operated Double Diaphragm Pump

	NDP-40BSC-HP	NDP-40BSN-HP	NDP-40BSE-HP	NDP-40BSV-HP	NDP-40BSH-HP	NDP-40BSS-HP	HIGH-PRESSURE PUMPS		
NPT	852641-HP	852637-HP	852642-HP	852640-HP	852638-HP	852712-HP	** NPT PUMPS **		
FLANGE	852419-HP	852223-HP	852420-HP	852301-HP	852224-HP	852710-HP	** FLANGE PUMPS **		
REF No.	PART No.	PART No.	PART No.	PART No.	PART No.	PART No.	DESCRIPTION	QTY.	REORDER
1	580960	580960	580960	580960	580960	580960	OUT CHAMBER	1	
1-HP	580960-HP	580960-HP	580960-HP	580960-HP	580960-HP	580960-HP	OUT CHAMBER-HP	1	
2	712599	712599	712599	712599	712599	712599	IN MANIFOLD-FLANGE	1	
2	712601	712601	712601	712601	712601	712601	IN MANIFOLD-NPT	1	
3	712598	712598	712598	712598	712598	712598	OUT MANIFOLD-FLANGE	1	
3	712600	712600	712600	712600	712600	712600	OUT MANIFOLD-NPT	1	
<b>5</b>	<b>803111-HP</b>	<b>803111-HP</b>	<b>803111-HP</b>	<b>803111-HP</b>	<b>803111-HP</b>	<b>803111-HP</b>	<b>BODY ASSEMBLY</b>	<b>1</b>	
5-1	711933	711933	711933	711933	711933	711933	AIR CHAMBER	2	
5-2	711936-HP	711936-HP	711936-HP	711936-HP	711936-HP	711936-HP	BODY ASSEMBLY	1	
5-3	772689	772689	772689	772689	772689	772689	THROAT BEARING	2	
5-4	711937	711937	711937	711937	711937	711937	SPRING	2	
5-5	771740	771740	771740	771740	771740	771740	VALVE SEAT	2	
5-6	832162	832162	832162	832162	832162	832162	PILOT VALVE ASSY.	2	
5-8	640020	640020	640020	640020	640020	640020	O-RING	2	
5-9	685444	685444	685444	685444	685444	685444	PACKING	2	
5-10	640029	640029	640029	640029	640029	640029	O-RING	2	
5-11	771742	771742	771742	771742	771742	771742	GASKET	2	
5-12	683812	683812	683812	683812	683812	683812	FLAT HEAD BOLD	12	
<b>5-13</b>	<b>802971</b>	<b>802971</b>	<b>802971</b>	<b>802971</b>	<b>802971</b>	<b>802971</b>	<b>VALVE BODY ASSY</b>	<b>1</b>	
5-13-1	711931	711931	711931	711931	711931	711931	VALVE BODY	1	
5-13-2	580999	580999	580999	580999	580999	580999	CAP A	1	
5-13-3	581000	581000	581000	581000	581000	581000	CAP B	1	
5-13-5	771735	771735	771735	771735	771735	771735	SPRING STOPPER	1	
5-13-6	712976	712976	712976	712976	712976	712976	RESET BUTTON	1	
5-13-8	771738	771738	771738	771738	771738	771738	GASKET	2	
5-13-9	685036	685036	685036	685036	685036	685036	BOLT	8	
5-13-12	805084	805084	805084	805084	805084	805084	C-SPOOL VAVLE ASSY.	1	
5-13-12 *1	803675	803675	803675	803675	803675	803675	SLEEVE ASSY.	1	
5-13-13	640005	640005	640005	640005	640005	640005	O-RING	1	
5-13-14	684128	684128	684128	684128	684128	684128	CUSHION	4	
5-14	771712	771712	771712	771712	771712	771712	GASKET	1	
5-15	684240	684240	684240	684240	684240	684240	BOLT	6	
5-18	684987	684987	684987	684987	684987	684987	PLAIN WASHER	12	
7	711900	711900	711900	711900	711900	711900	CENTER ROD	1	
8	711902	711902	711902	711902	711902	711902	CENTER DISK	2	
9	711903	711903	711903	711903	711903	711903	CENTER DISK	2	
10	771853	771700	771854	771799	771701	771975	DIAPHRAGM	2	
11	771956	771994	771921	771997	771793	772003	VALVE SEAT	2	
11-HP	711908-HP	711908-HP	711908-HP	711908-HP	711908-HP	711908-HP	VALVE SEAT-HP	2	
12	770550	770584	770593	770602	770584	770593	BALL	2	
14	684321	684321	684321	684321	684321	684321	BALL VALVE	1	
15	682523	682523	682523	682523	682523	682523	ELBOW	1	
16	684339	684339	684339	684339	684339	684339	BUSHING	1	
19	711911	711911	711911	711911	711911	711911	PUMP BASE	2	
20	771402	771402	771402	771402	771402	771402	CUSHION	4	
21	683408	683408	683408	706128	683408	683408	NUT	2	

Air Operated Double Diaphragm Pump

	NDP-40BSC-HP	NDP-40BSN-HP	NDP-40BSE-HP	NDP-40BSV-HP	NDP-40BSH-HP	NDP-40BSS-HP	HIGH-PRESSURE PUMPS			
NPT	852641-HP	852637-HP	852642-HP	852640-HP	852638-HP	852712-HP	** NPT PUMPS **			
FLANGE	852419-HP	852223-HP	852420-HP	852301-HP	852224-HP	852710-HP	** FLANGE PUMPS **			
REF No.	PART No.	PART No.	PART No.	PART No.	PART No.	PART No.	DESCRIPTION	QTY.	REORDER	
22	682740	682740	682740	682740	682740	682740	CONED DISK SPRING	2		
23	621180	621180	621180	621180	621180	621180	BOLT	16		
	631937	631937	631937	631937	631937	631937	WAVE SPRING WASHER	16		
24	631174	631174	631174	631174	631174	631174	PLAIN WASHER	4		
25	631937	631937	631937	631937	631937	631937	WAVE SPRING WASHER	4		
26	621202	621202	621202	621202	621202	621202	BOLT	12		
27	631175	631175	631175	631175	631175	631175	PLAIN WASHER	12		
28	631938	631938	631938	631938	631938	631938	WAVE SPRING WASHER	12		
29	628014	628014	628014	628014	628014	628014	NUT	12		
33	621175	621175	621175	621175	621175	621175	BOLT	4		
34	628013	628013	628013	628013	628013	628013	NUT	4		
35	611149	611149	611149	611149	611149	611149	BOLT	4		
36	682276	682276	682276	682276	682276	682276	NUT W/FLANGE	4		
40	640065	640065	683999	642065	640065	683999	O-RING	4		
44	804764	804764	804764	804764	804764	804764	MUFFLER	1		
51	770582	770582	770582	770582	770582	770582	CUSHION	2		
KIT							K45-AM		AIR MOTOR KIT	

Not Shown: Hose Assembly with Fittings

General Tools:

- Socket wrench - 24mm
- Hexagonal box wrench - 5mm, 6mm
- Small crowbars—2 (C/N/E/V)
- Open-end wrench - 19mm, 24mm
- Plastic hammer

Special Tools:

- Sleeve remover (713180) used for removing the sleeve (sold separately)

Miscellaneous:

- Assembly Oil - Turbine oil none additional class 1 (equivalent to ISO VG32 grade)
- Nuts - M16 x 1.5
- Thread Locker
- Urea grease grade (NLGI) No. 2

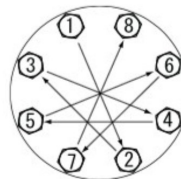

Tightening torque for center rod and out chambers.

- Center Rod 43 ft-lbf {60 N-m}
- Out Chambers 29 ft-lbf {40 N-m}

Tightening torque for manifold retainer bolts.

- BS\_HP 18 ft-lbf {25 N-m}

Customer Notes

Model #: \_\_\_\_\_  
 Description: \_\_\_\_\_  
 Serial #: \_\_\_\_\_  
 Date Installed: \_\_\_\_\_  
 Department Location: \_\_\_\_\_  
 Tag/Project: \_\_\_\_\_