

# EXPLODED VIEW & PARTS LISTING

## Air Operated Double Diaphragm Pump

Model: NDP-50BP[x]  
Polypropylene Series  
(w/metal center body)



### To Purchase:

- ☎ 800-990-7867
- ✉ sales@yamadapump.com
- 📍 Find My Rep

### More Information:

- ▶ YouTube: @yamadapump
- 🌐 yamadapump.com
- Data Sheets | CAD Drawings | Manuals Literature | BOM | Performance Curves

### Trial Program

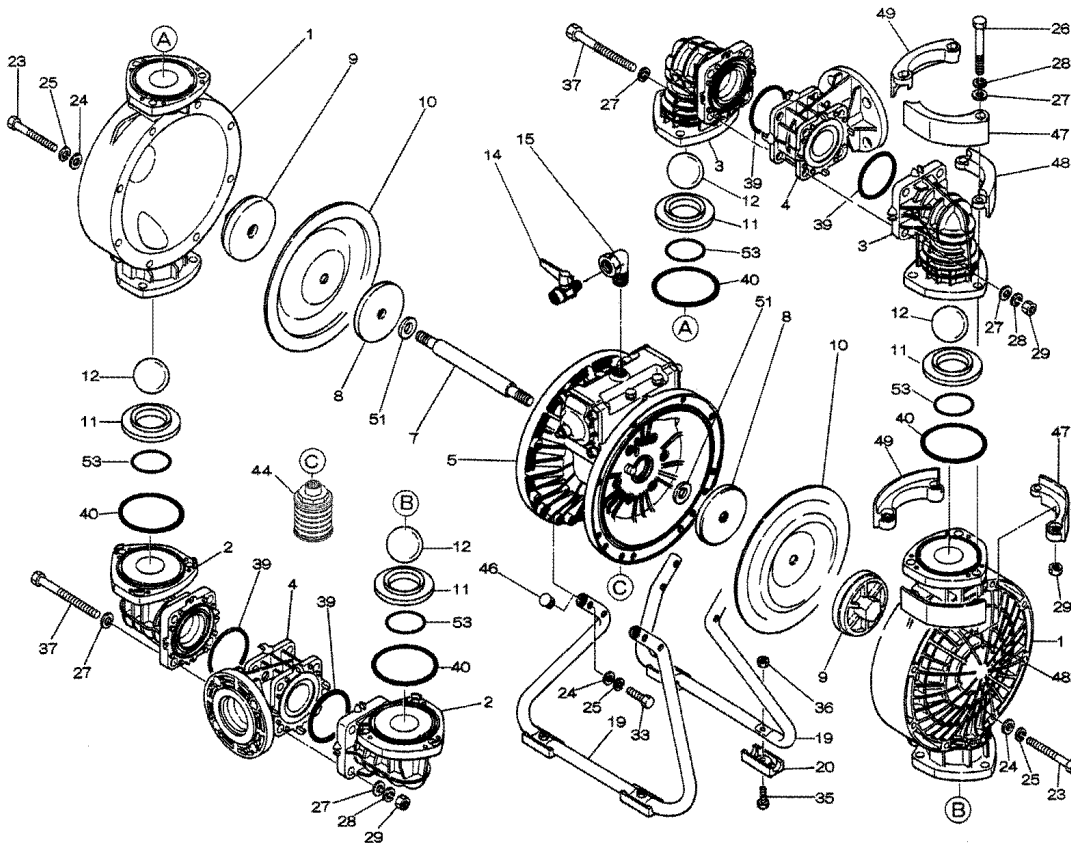

■Body Assembly



■Valve Body Assembly

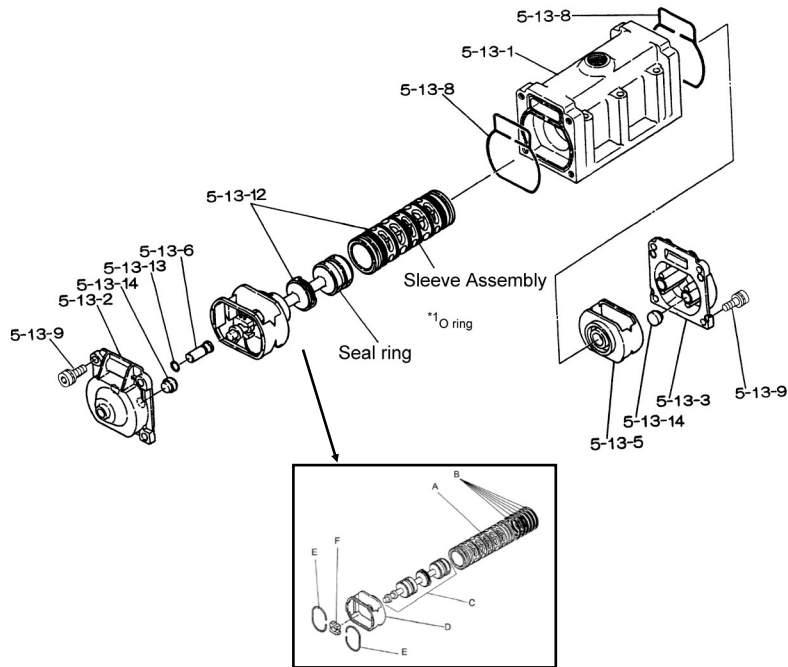

## Air Operated Double Diaphragm Pump

	NDP-50BPC	NDP-50BPE	NDP-50BPN	NDP-50BPH	NDP-50BPS	NDP-50BPV			
	852427	852428	852235	852236	852719	852305			
REF. NO.	PART NO.	PART NO.	PART NO.	PART NO.	PART NO.	PART NO.	DESCRIPTION	QTY	REORDER
1	780148	780148	780148	780148	780148	780148	OUT CHAMBER	2	
2	780245	780245	780245	780245	780245	780245	IN MANIFOLD	2	
3	780151	780151	780151	780151	780151	780151	OUT MANIFOLD	2	
4	780249	780249	780249	780249	780249	780249	CENTER MANIFOLD	2	
<b>5</b>	<b>803112</b>	<b>803112</b>	<b>803112</b>	<b>803112</b>	<b>803112</b>	<b>803112</b>	<b>CENTER BODY ASSY.</b>	<b>1</b>	
5-1	711934	711934	711934	711934	711934	711934	AIR CHAMBER 50	2	
5-2	711936	711936	711936	711936	711936	711936	BODY	1	
5-3	772689	772689	772689	772689	772689	772689	THROAT BEARING	2	
5-4	711937	711937	711937	711937	711937	711937	PILOT VALVE SPRING	2	
5-5	771740	771740	771740	771740	771740	771740	PILOT VALVE SEAT	2	
5-6	832162	832162	832162	832162	832162	832162	PILOT VALVE ASSY.	2	
5-8	640020	640020	640020	640020	640020	640020	O-RING	2	
5-9	685444	685444	685444	685444	685444	685444	V-PACKING	2	
5-10	640029	640029	640029	640029	640029	640029	O-RING	2	
5-11	771742	771742	771742	771742	771742	771742	GASKET	2	
5-12	683812	683812	683812	683812	683812	683812	BOLT	12	
<b>5-13</b>	<b>802971</b>	<b>802971</b>	<b>802971</b>	<b>802971</b>	<b>802971</b>	<b>802971</b>	<b>VALVE BODY ASSY</b>	<b>1</b>	
5-13-1	711931	711931	711931	711931	711931	711931	VALVE BODY	1	
5-13-2	580999	580999	580999	580999	580999	580999	CAP A	1	
5-13-3	581000	581000	581000	581000	581000	581000	CAP B	1	
5-13-5	771735	771735	771735	771735	771735	771735	SPRING RETAINER	1	
5-13-6	712976	712976	712976	712976	712976	712976	RESET BUTTON	1	
5-13-8	771738	771738	771738	771738	771738	771738	GASKET	2	
5-13-9	685036	685036	685036	685036	685036	685036	SOCKET BOLT	8	
<b>5-13-12</b>	<b>805084</b>	<b>805084</b>	<b>805084</b>	<b>805084</b>	<b>805084</b>	<b>805084</b>	<b>C SPOOL ASSY.</b>	<b>1</b>	
A	803675	803675	803675	803675	803675	803675	SLEEVE ASSY.	1	
B	640036	640036	640036	640036	640036	640036	O-RING	6	
C	805085	805085	805085	805085	805085	805085	SPOOL ASSY.	1	
D	771735	771735	771735	771735	771735	771735	SPRING RETAINER	1	
E	711932	711932	711932	711932	711932	711932	C-SPRING	2	
F	771734	771734	771734	771734	771734	771734	BLOCK	1	
5-13-13	640005	640005	640005	640005	640005	640005	O-RING	1	
5-13-14	684128	684128	684128	684128	684128	684128	CUSHION	4	
<b>5-14</b>	<b>771712</b>	<b>771712</b>	<b>771712</b>	<b>771712</b>	<b>771712</b>	<b>771712</b>	<b>GASKET FOR VALVE BODY</b>	<b>1</b>	
5-15	684240	684240	684240	684240	684240	684240	BOLT W/WASHER	6	
5-18	684987	684987	684987	684987	684987	684987	WASHER	12	
7	711900	711900	711900	711900	711900	711900	CENTER ROD	1	
8	711904	711904	711904	711904	711904	711904	CENTER DISK 50-R	2	
9	771727	771727	771727	771727	771727	771727	CENTER DISK 50PP-R	2	
10	771855	771856	771702	771703	771976	771800	DIAPHRAGM 50	2	
11	772097	772097	772097	772097	772097	772097	VALVE SEAT	4	
12	770627	770633	770630	773143	773173	770636	BALL 50	4	
14	686974	686974	686974	686974	686974	686974	BALL VALVE 3/4"	1	
15	682523	682523	682523	682523	682523	682523	ELBOW STRT 3/4" 90D	1	
19	711926	711926	711926	711926	711926	711926	STAND	2	
20	771865	771865	771865	771865	771865	771865	FOOT RUBBER	4	
23	686156	686156	686156	686156	686156	686156	BOLT	16	

Air Operated Double Diaphragm Pump

REF. NO.	NDP-50BPC	NDP-50BPE	NDP-50BPN	NDP-50BPH	NDP-50BPS	NDP-50BPV	DESCRIPTION	QTY	REORDER
	852427	852428	852235	852236	852719	852305			
24	631330	631330	631330	631330	631330	631330	FLAT WASHER	24	
25	680257	680257	680257	680257	680257	680257	SPRING WASHER	24	
26	621213	621213	621213	621213	621213	621213	BOLT	12	
27	631331	631331	631331	631331	631331	631331	FLAT WASHER	28	
28	680607	680607	680607	680607	680607	680607	SPRING WASHER	20	
29	628014	628014	628014	628014	628014	628014	NUT	20	
33	621179	621179	621179	621179	621179	621179	BOLT	8	
35	621149	621149	621149	621149	621149	621149	BOLT	4	
36	683837	683837	683837	683837	683837	683837	NUT W/FLANGE	4	
37	684592	684592	684592	684592	684592	684592	BOLT	8	
39	640064	684121	640064	640064	684121	642064	O-RING	4	
40	640069	684122	640069	640069	684122	642069	O-RING	4	
44	804764	804764	804764	804764	804764	804764	SILENCER	1	
46	683641	683641	683641	683641	683641	683641	CAP STAND	4	
47	771786	771786	771786	771786	771786	771786	PROTECTOR A	8	
48	771787	771787	771787	771787	771787	771787	PROTECTOR B	8	
49	771788	771788	771788	771788	771788	771788	PROTECTOR C	8	
51	770582	770582	770582	770582	770582	770582	CUSHION	2	
53	640139	685448	640139	640139	685448	642139	O-RING	4	
KIT	K50-PC	K50-PE	K50-PN	K50-PH	K50-PS	K50-PV	LIQUID END KIT		
KIT	K45-AM						AIR MOTOR KIT		

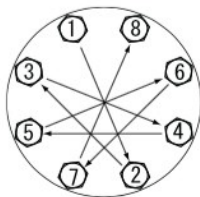

**Tightening torque for center rod and out chambers.**

- Center Rod 36 ft-lbf {50 N-m}
- Out Chambers 26 ft-lbf {35 N-m}

**Tightening torque for manifold retainer bolts.**

- BPC/E/H/N/S/V 18 ft-lbf {25 N-m}

**General Tools:**

- Socket wrenches - 13mm, 17mm, 19mm, 24mm
- Hexagonal box wrench - 5mm, 6mm
- Small crowbars - 2 (C/N/E/V)
- Plastic hammer

**Special Tools (sold separately):**

- Sleeve remover (713180).
- PP wrench to remove the center disk (771868)

**Miscellaneous:**

- Assembly Oil - turbine oil class 1 (equivalent to ISO VG32 grade)
- Nuts - M16 x 1.5
- Thread locker
- Urea grease grade (NLGI) No. 2

Customer Notes	
Model #:	_____
Description:	_____
Serial #:	_____
Date Installed:	_____
Department Location:	_____
Tag/Project:	_____