

# EXPLODED VIEW & PARTS LISTING

## Air Operated Double Diaphragm Pump

Model: NDP-80BF[x]  
Cast Iron Series



### To Purchase:

- 800-990-7867
- sales@yamadapump.com
- Find My Rep

### More Information:

- YouTube: @yamadapump
- yamadapump.com
- Data Sheets | CAD Drawings | Manuals Literature | BOM | Performance Curves

### Trial Program

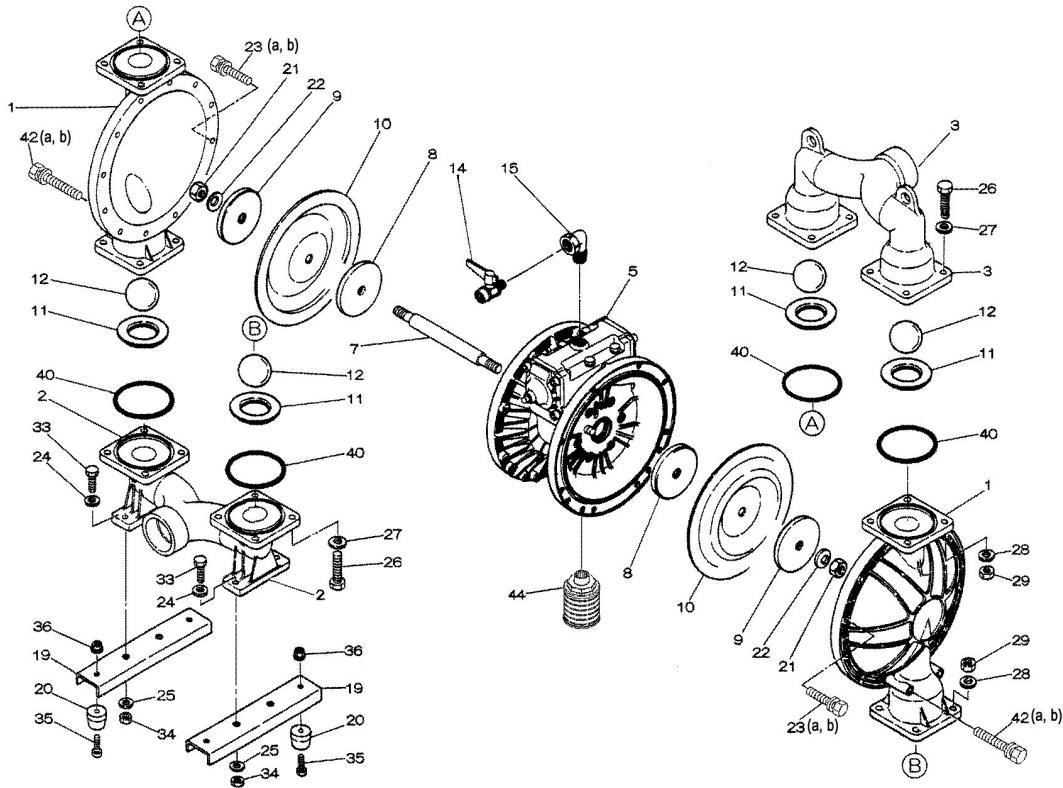

Air Operated Double Diaphragm Pump

■ Body Assembly



■ Valve Body Assembly

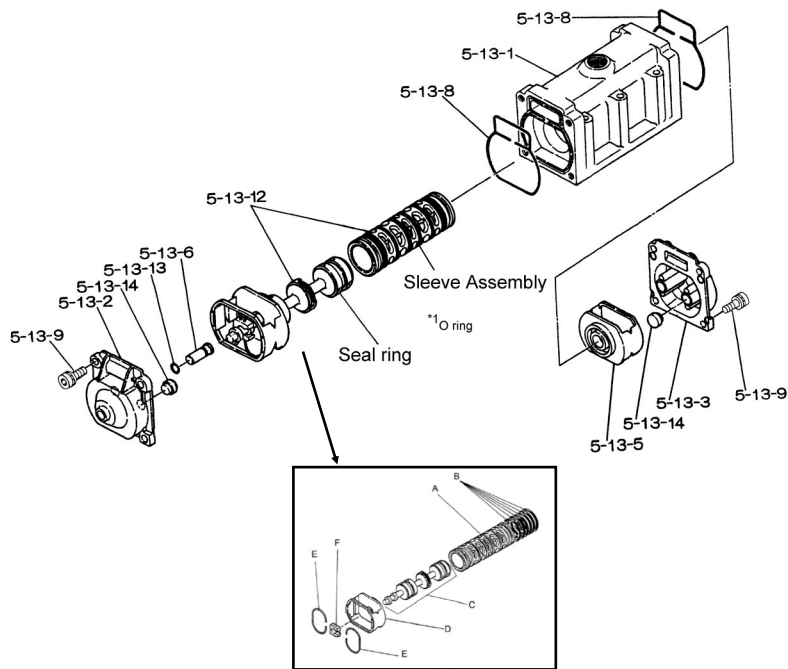

Air Operated Double Diaphragm Pump

	NDP-80BFC	NDP-80BFN	NDP-80BFE	NDP-80BFH	NDP-80BFS	NDP-80BFV	** NPT PUMPS **		
NPT	852859	852855	852860	852856	852861	852858			
REF. No.	PARTS No.	PARTS No.	PARTS No.	PARTS No.	PARTS No.	PARTS No.	DESCRIPTION	QTY.	REORDER
1	713158	713158	713158	713158	713158	713158	OUT CHAMBER	2	
2	713170	713170	713170	713170	713170	713170	IN MANIFOLD	1	
3	713167	713167	713167	713167	713167	713167	OUT MANIFOLD	1	
5	803113	803113	803113	803113	803113	803113	CENTER BODY ASSY.	1	
5- 1	711935	711935	711935	711935	711935	711935	AIR CHAMBER	2	
5- 2	711936	711936	711936	711936	711936	711936	BODY	1	
5- 3	780325	780325	780325	780325	780325	780325	THROAT BEARING	2	
5- 4	711937	711937	711937	711937	711937	711937	PILOT VALVE SPRING	2	
5- 5	771740	771740	771740	771740	771740	771740	PILOT VALVE SEAT	2	
5- 6	832163	832163	832163	832163	832163	832163	PILOT VALVE ASSY.	2	
5- 8	640020	640020	640020	640020	640020	640020	O-RING	2	
5- 9	685444	685444	685444	685444	685444	685444	V-PACKING	2	
5-10	640029	640029	640029	640029	640029	640029	O-RING	2	
5-11	771742	771742	771742	771742	771742	771742	GASKET	2	
5-12	683812	683812	683812	683812	683812	683812	FLAT SOCKET BOLT	12	
5-13	802971	802971	802971	802971	802971	802971	VALVE BODY ASSY.	1	
5-13-1	711931	711931	711931	711931	711931	711931	VALVE BODY	1	
5-13-2	580999	580999	580999	580999	580999	580999	CAP A	1	
5-13-3	581000	581000	581000	581000	581000	581000	CAP B	1	
5-13-5	771735	771735	771735	771735	771735	771735	SPRING RETAINER	1	
5-13-6	712976	712976	712976	712976	712976	712976	RESET BUTTON	1	
5-13-8	771738	771738	771738	771738	771738	771738	GASKET	2	
5-13-9	685036	685036	685036	685036	685036	685036	SOCKET BOLT	8	
5-13-12	805084	805084	805084	805084	805084	805084	C-SPOOL ASSY.	1	
A	803675	803675	803675	803675	803675	803675	SLEEVE ASSY.	1	
B	640036	640036	640036	640036	640036	640036	O-RING	6	
C	805085	805085	805085	805085	805085	805085	SPOOL ASSY.	1	
D	771735	771735	771735	771735	771735	771735	SPRING RETAINER	1	
E	711932	711932	711932	711932	711932	711932	C-SPRING	2	
F	771734	771734	771734	771734	771734	771734	BLOCK	1	
5-13-13	640005	640005	640005	640005	640005	640005	O-RING	1	
5-13-14	684128	684128	684128	684128	684128	684128	CUSHION	4	
5-14	771712	771712	771712	771712	771712	771712	GASKET	1	
5-15	684240	684240	684240	684240	684240	684240	BOLT W/WASHERS	6	
5-18	684987	684987	684987	684987	684987	684987	WASHER	12	
7	711901	711901	711901	711901	711901	711901	CENTER ROD	1	
8	711906	711906	711906	711906	711906	711906	CENTER DISK (INNER)	2	
9	713371	713371	713371	713371	713371	713371	CENTER DISK (OUTER)	2	
10	771857	771704	771858	771705	771977	771801	DIAPHRAGM	2	
11	771958	771996	771999	771795	772005	771998	VALVE SEAT	4	
12	770559	770587	770596	773144	773174	770605	BALL	4	
14	686974	686974	686974	686974	686974	686974	BALL VALVE	1	
15	682523	682523	682523	682523	682523	682523	ELBOW	1	
19	711912	711912	711912	711912	711912	711912	BASE	2	
20	771402	771402	771402	771402	771402	771402	FOOT RUBBER	4	
21	683408	683408	683408	683408	683408	683408	NUT	2	
22	682740	682740	682740	682740	682740	682740	WASHER	2	
23a	686161	686161	686161	686161	686161	686161	BOLT	20	
23b	631917	631917	631917	631917	631917	631917	WAVE WASHER	20	

Air Operated Double Diaphragm Pump

	NDP-80BFC	NDP-80BFN	NDP-80BFE	NDP-80BFH	NDP-80BFS	NDP-80BFV			
NPT	852859	852855	852860	852856	852861	852858	** NPT PUMPS **		
REF. No.	PARTS No.	PARTS No.	PARTS No.	PARTS No.	PARTS No.	PARTS No.	DESCRIPTION	QTY.	REORDER
24	631014	631014	631014	631014	631014	631014	FLAT WASHER	4	
25	631917	631917	631917	631917	631917	631917	WAVE WASHER	4	
26	611204	611204	611204	611204	611204	611204	BOLT	16	
27	631015	631015	631015	631015	631015	631015	FLAT WASHER	16	
28	631918	631918	631918	631918	631918	631918	WAVE WASHER	16	
29	627014	627014	627014	627014	627014	627014	NUT	16	
33	611177	611177	611177	611177	611177	611177	BOLT	4	
34	627013	627013	627013	627013	627013	627013	NUT	4	
35	611149	611149	611149	611149	611149	611149	BOLT	4	
36	682276	682276	682276	682276	682276	682276	NUT W/FLANGE	4	
40	640078	640078	684124	640078	684124	642078	O-RING	4	
42	686164	686164	686164	686164	686164	686164	BOLT	4	
42	631917	631917	631917	631917	631917	631917	WAVE WASHER	4	
44	804764	804764	804764	804764	804764	804764	SILENCER ASSY.	1	
KIT	K80-MC	K80-MN	K80-ME	K80-MH	K80-MS	K80-MV	LIQUID SIDE KIT		
KIT	K80-AM						AIR MOTOR KIT		

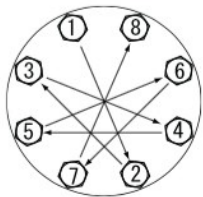

**Tightening torque for center rod and out chambers.**

- Center Rod 43 ft-lbf {60 N-m}
- Out Chambers 29 ft-lbf {40 N-m}

**Tightening torque for manifold retainer bolts.**

- BFC/E/H/N/S/V 18 ft-lbf {25 N-m}

**General Tools:**

- Socket wrenches - 24mm
- Hexagonal box wrench - 5mm, 6mm
- Small crowbars - 2 (C/N/E/V)
- Open-end wrenches - 19mm, 24mm
- Plastic hammer

**Special Tools:**

- Sleeve remover (713180) (sold separately)

**Miscellaneous:**

- Assembly Oil - turbine oil class 1 (equivalent to ISO VG32 grade)
- Nuts - M16 x 1.5
- Thread locker
- Urea grease grade (NLGI) No. 2

Customer Notes	
Model #:	_____
Description:	_____
Serial #:	_____
Date Installed:	_____
Department Location:	_____
Tag/Project:	_____